

Smile Line ☺
made in Switzerland

“The future is not
what is going to
happen to us but what
we are going to do”

(Henri Bergson 1859-1941)

This quote probably makes sense for you due to the amazing changes and evolution in our technology during the last several years. In order to not be rapidly overtaken, everyone has had to make decisions and choices for their future.

It is not only focused on technical choices. These choices also concern the human factor and the communication aspects. More than ever, if the aim of the industry is the research for excellence, then a strong partnership and real teamwork between the laboratory, the dental office and the patient are the main focus of your preoccupations.

With this conviction, Smile Line innovates excellence this year with the arrival on the market of a brand new and unique tool that makes communication among this partnership so simple: Smile Lite MDP, presented on pages 50-51.

Shaping the future is also a personal choice of continued education for gathering knowledge, acquiring more experience and promoting exchanges of quality information.

It is for promoting this kind of emulation that Smile Line has invested in a high-end education center at the forefront of design and modernity – to be discovered on page 68. We created it to offer you new possibilities of improvements in skill and learning while meeting with internationally renowned experts in a unique environment. Our hope is to have the pleasure to welcome you soon.

Finally if the success of any company is closely linked with innovation and promotion of projects, our passion is the engine for setting them up. More than anything, we wish that this passion accompanies you every day, just as it is the case at Smile Line!

With our best wishes of success and wishing you an enjoyable reading experience.

Olivier Schaeren
Smile Line CEO



I CREATE...
WE CREATE

www.smileline.ch

SMILELINE 2017



INDEX

CERAMIC INSTRUMENTS	04-19
Handles and base modules	06-07
Ceramic brushes and instruments modules	08-09
Porcelain instrument set	10
Equilibrium	11
FlexMount	12-13
N.era brushes	14-15
N.era bRRRush	16-17
N.era [Njoy]	18
H ₂ O	19
MIXING TRAYS FOR PORCELAIN	20-31
Wet'n'Dry SlimPad	22-25
Wet'n'Dry EVO3	26-27
U-mid Classic	28
U-mid EVO 3	29
Tinto	30-31
WAX AND COMPOSITE	32-39
Wax set and instruments modules	34
High Precision Waxes	35
N-Architect, Anterior silicone moulds	36
N-Architect, Posterior silicone moulds	37
Composite set and instruments modules	38
Compo-Brush	39
IMPLANTOLOGY ACCESSORIES	40-45
Implant drivers for laboratory	42-43
Sidekick, Implant drivers for dentists	44-45
SHADE TAKING, PHOTOGRAPHY	46-55
Smile Lite	48-49
Smile Lite MDP	50-51
Flexipalette	52
Photo-CAD	53
My Shade Guide	54
Sampler	55
ACCESSORIES	56-65
Micro-Vibes	58
United Colors by D.Vinci	59
Golden Section	60-61
venerME	62
Holding Gel	63
Zir.Care	64
Organ.ez	65
CONCLUSION	66-67
EDUCATION CENTER	68

CERAMIC INSTRUMENTS

SMILELINE 2017



100% Modular

INSTRUMENT

BY SMILE LINE

SMILELINE 2017

Excellence and ergonomics

Outstanding, exclusive and custom tailored, **Instrument by Smile Line** is 100% modular and allows you the possibility for almost unlimited combinations to complete your selection.

On more than 10 pages, we unveil the ultimate in matter of porcelain instruments, starting here under with the a wide variety of choice of handles. All are manufactured with an extreme care out of **highest quality noble materials**: anodized black aluminum, carbon fiber and three different precious wood species.

Select what best matches with your personality and taste.

HANDLES

BLACK ANODIZED ALUMINUM



4000-As
Grooved handle, short

4000-A
Grooved handle, standard

4000-AH
Grooved single handle, hollow

CARBON FIBER



4100-CAs
Carbon fiber handle, short

4100-CA
Carbon fiber handle, standard

4100-CAL
Carbon fiber handle, long, single-end

PALISSANDER



4100-PAs
Palissander handle, short

4100-PA
Palissander handle, standard

EBONY



4100-PAL
Palissander handle, long, single-end

4100-EBs
Ebony of Mozambique handle, short

4100-EB
Ebony of Mozambique handle, standard

VIOLETT WOOD



4100-EBL
Ebony of Mozambique handle, long, single-end

4100-VIs
Violett wood handle, short

4100-VI
Violett wood handle, standard

4100-VIL
Violett wood handle, long, single-end

4000-BC
Instrument end cut

**BRUSH AND PORCELAIN
INSTRUMENTS MODULES**

SMILELINE 2017

Highest quality and precision

Our brushes selected out of first and finest quality Kolinsky hair are your everyday companions in your search for excellence.

Our spatulas, layering or cut-back tools, tweezers have become essential tools for thousands of ceramists worldwide.



4100-XR Kolinsky brush tip #8-R	4100-XLT Kolinsky brush tip #8-LT	4000-V6 Kolinsky brush tip #6 module	4000-W Kolinsky brush tip #4 module	4000-MOS Kolinsky brush tip #3 module, S. Mosconi	4000-N Glaze brush #2 module	4000-O Stains brush #3/0 module	4000-VD DUST brush module	4000-SG1 Soft-Grip module, single	4000-SG2 Soft-Grip module, double	4000-SG3 Soft-Grip module, mini	4000-ZR Zircone spatula module	4000-OP1 Opaque instrument module, small Al ₂ O ₃ bead	4000-OP2 Opaque instrument module, large Al ₂ O ₃ bead	4000-R Condensor, pin ejector module	4000-Q Spoon module, long
		4001-V6 (2 pcs) Brush tips #6	4001-W (3 pcs) Brush tips #4		4001-N (5 pcs) Brush tips #2	4001-O (5 pcs) Brush tips #3/0		4010-SG1 Complete instrument (4000-A + BS + SG1)	4010-SG2 Complete instrument (4000-A + BS + SG2)	4010-SG3 Complete instrument (4000-A + BS + SG3)		4001-OP1 Refill beads (2 pcs)	4001-OP2 Refill beads (2 pcs)		

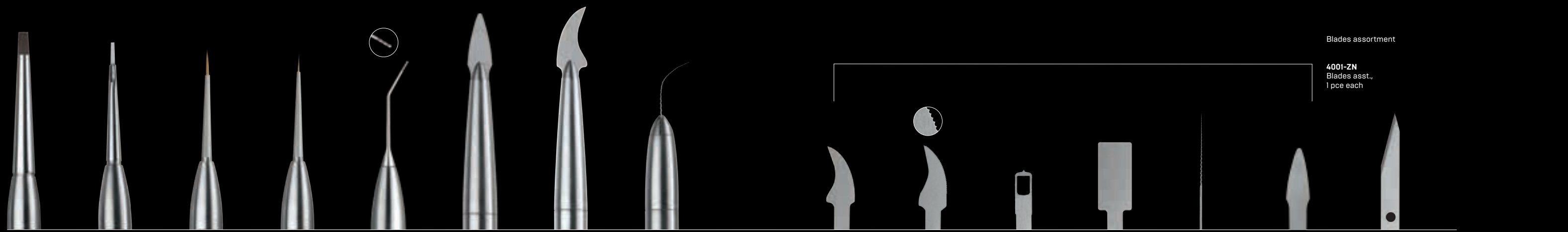

4000-LO Paste opaque brush module, large	4000-M Paste opaque brush module, small	4000-Sy0 SynTec brush #0 module	4000-Sy3/0 SynTec brush #3/0 module	4000-STE Depth probe for raw porcelain module, graduated 0.5 mm	4000-P5 Flexible spatula 0.1 mm module	4000-P Porcelain blade module	4000-CR Hedstroem reamer module	4001-P Standard blade 75 µ (5 pcs)	4001-P1 Microsaw blade 75 µ (5 pcs)	4001-P2 Hollow blade 75 µ (5 pcs)	4001-P3 Blank blade 75 µ (5 pcs)	4001-P4 Hedstroem reamer (3 pcs)	4001-P5 Flexible spatula 0.1 mm (5 pcs)	4001-CS Scalpel blade (10 pcs)
4001-LO (5 pcs) Brush tips	4001-M (5 pcs) Brush tips	4001-Sy0 (5 pcs) SynTec brush tips #0	4001-Sy3/0 (5 pcs) SynTec brush tips #3/0											

Blades assortment

4001-ZN
Blades asst., 1 pce each

PORCELAIN INSTRUMENT SET

SMILELINE 2017

Simply because you have passion for what you do

The "porcelain set" is tailored to your needs. Part of the tools are pure Smile Line developments and innovations (ZR spatula – opaque instrument – Soft-Grip – condensing instrument). Some are more traditional like for example the cut-back tools (xx-thin blades – file– spoon). Finally the quality of the Kolinsky brushes is the highest and of best selection. Each Kolinsky brush tip is **severely quality controlled** according to new strict standards implemented with our partner Pinselmeister.

We are convinced that this tool kit will follow you during years of creating dental artistry. You are going to arouse envy around you!

Important information: for those of you who prefer creating their dental artwork with our exclusive **N.era** brushes, the same instrument set exists in a "N.era configuration" instead of Kolinsky.



Description	Item no.
Porcelain instrument set, highest quality Kolinsky brushes (#8-R and #3/0), total 8 tools for 6 black anodized aluminum grooved handles, assortment of x-thin cut-back blades, micro-fiber tissue	14050-K
Porcelain instrument set, with N.era fiber brushes (#8 and #1), total 8 tools for 6 black anodized aluminum grooved handles, assortment of x-thin cut-back blades, micro-fiber tissue	14050-N
Empty instrument case, mat laminated cardboard, closure with magnets, micro-fiber tissue	14999



EQUILIBRIUM

An instrument stand worth your personal fine tools



Description	Item no.
Equilibrium, instrument stand (instruments not included)	14002

Made in Switzerland out of high quality stainless steel, aluminum and composite panels.

Its construction and **specific cantilever design** make it so elegant and unique. On your bench it doesn't leave anyone indifferent!



FLEXMOUNT

Simple – as the great ideas

SMILELINE 2017

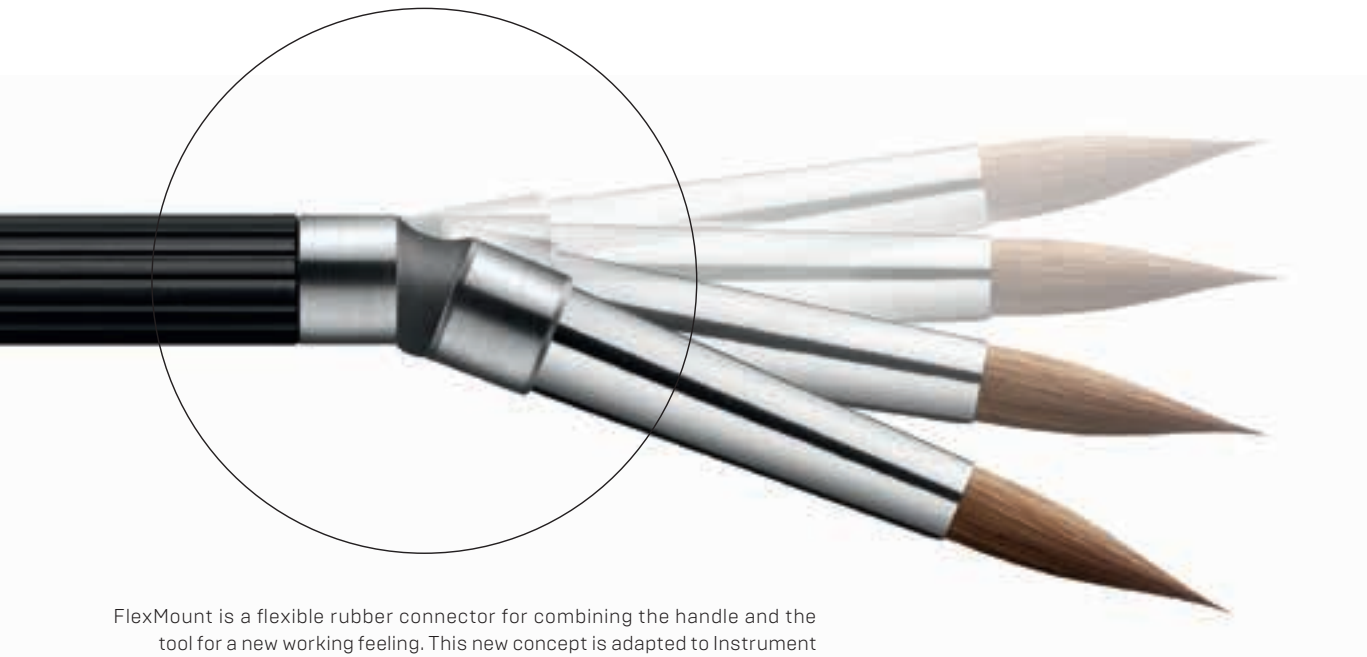

FlexMount is a flexible rubber connector for combining the handle and the tool for a new working feeling. This new concept is adapted to Instrument by Smile Line, more specifically to our ZR mixing spatula and our porcelain brushes.

For a Smile Line brush: with a gentle snap, you activate the front part of your brush tip and **“accelerate” the required moisture from the brush belly towards the point, re-shaping it** in the same time.

For the ZR spatula: FlexMount works as a **shock absorber** and allows for maximum comfort and feeling during mixing of porcelain or stains, preserving in the same time the thin ZR spatula.



FLEXIBLE CONNECTOR



FL-4000
Flexible connector
(2 pcs)

TIPS



4000-ZR
Zirconia mixing spatula, module

4201-SF-8
N.era brush tip #8, short ferrule (2 pcs)

4000-SF-8R
Kolinsky brush tip #8R, short ferrule

4000-SF-6
Kolinsky brush tip #6, short ferrule

FL-4020-ZR
Zirconia mixing spatula, on flexible connector

FL-4220-SF-8
N.era brush tip #8, short ferrule, on flexible connector

FL-4020-SF-8R
Kolinsky brush tip #8R, short ferrule, on flexible connector

FL-4020-SF-6
Kolinsky brush tip #6, short ferrule, on flexible connector

Note: for the FlexMount concept we developed brush tips equipped with a shorter ferrule to increase the spring/elasticity.

For allowing you to take advantage of the FlexMount technology, we offer you different executions of ready mounted instruments sets. Each contains a ZR spatula and a porcelain build up brush – all details and references on the right.

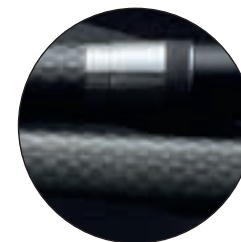

CARBON FIBER

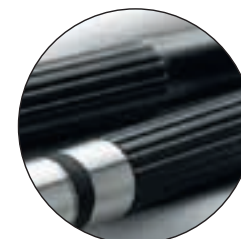

ANODIZED ALUMINUM

CARBON FIBER handle sets:

	Item no.
Instruments for ceramic, set of 2 (Kolinsky brush #6 & zirconia spatula) on flexible connector – Carbon fiber handles	FL-14150-CA6
Instruments for ceramic, set of 2 (Kolinsky brush #8R & zirconia spatula) on flexible connector – Carbon fiber handles	FL-14150-CAB8K
Instruments for ceramic, set of 2 (N.era brush #8 & zirconia spatula) on flexible connector – Carbon fiber handles	FL-14150-CA8N

BLACK ANODIZED ALUMINUM handle sets:

	Item no.
Instruments for ceramic, set of 2 (Kolinsky brush #6 & zirconia spatula) on flexible connector – Black anodized aluminum handles	FL-14150-6
Instruments for ceramic, set of 2 (Kolinsky #8R & spatula zirconia) on flexible connector – Black anodized aluminum handles	FL-14150-8K
Instruments for ceramic, set of 2 (Brush N.era #8 & spatula zirconia) on flexible connector – Black anodized aluminum handles	FL-14150-8N

N.ERA BRUSHES

SMILELINE 2017

8-MACCHIATO

6-CAPPUCCINO

4-MOKA

1-RISTRETTO



4200-8
N.era #8
Complete brush

4200-6
N.era #6
Complete brush

4200-4
N.era #4
Complete brush

4200-1
N.era #1
Complete brush

4201-8
Spare tips
N.era #8 (2 pcs)

4201-6
Spare tips
N.era #6 (2 pcs)

4201-4
Spare tips
N.era #4 (2 pcs)

4201-1
Spare tips
N.era #1 (2 pcs)

Beyond the references
of precision for
porcelain build-up!

N.era represents “nera” (black in Italian – the color of their ferrule) or “new era”. Smile Line’s N.era porcelain brushes are made out of an artificial filament of a new era, exclusive and never seen yet in our industry. We are talking here of a polyamide type filament which undergoes several special chemical treatments.

It clearly becomes a **challenge to find another brush that has a tip that sharp, stable, and resilient in the same time** in daily operation! Our pilot laboratories and users speak highly about N.era and are very enthusiastic about this innovation. N.era brushes are setting a **new working comfort and new possibilities for the precision during porcelain build up.**

Other unique and very interesting advantage: it is enough to thoroughly clean a N.era tip with the steamjet for regenerating it. It will spring back into the original shape and this is what makes a N.era brush’s life long, very long.



4200-Asst
N.era brush complete set:
8-Macchiato, 6-Cappuccino, 4-Moka, 1-Ristretto

Description	Item no.
Aluminum handle - Macchiato	4000-AH-MAC
Aluminum handle - Cappuccino	4000-AH-CAP
Aluminum handle - Moka	4000-AH-MOK
Aluminum handle - Ristretto	4000-AH-RIS

N.ERA BRRRUSH

SMILELINE 2017

While bRRRush is using the revolutionary N.era tips, a unique "vibe zone" has been machined on its handle.

When letting the nail of your forefinger stroke back and forth on the surface, you create a micro-vibration which propagates up to the very end of your brush tip. The small portion of porcelain on your brush will almost "detach" while transforming itself into a small drop very easy to apply to your build-up. A short video clip on Smile Line's website shows you how impressive it is.

The advantage of this technique lies in the fact that much less air is integrated in the porcelain during build-up, **synonymous with less porosities in the porcelain after firing – spectacular especially in the incisal area.**



4200-bRRR-8 N.era bRRRush #8, complete brush	4200-bRRR-6 N.era bRRRush #6, complete brush	4200-bRRR-4 N.era bRRRush #4, complete brush
4201-8 Spare tips #8 (2 pcs)	4201-6 Spare tips #6 (2 pcs)	4201-4 Spare tips #4 (2 pcs)

Pre-condense your porcelain
right during its application

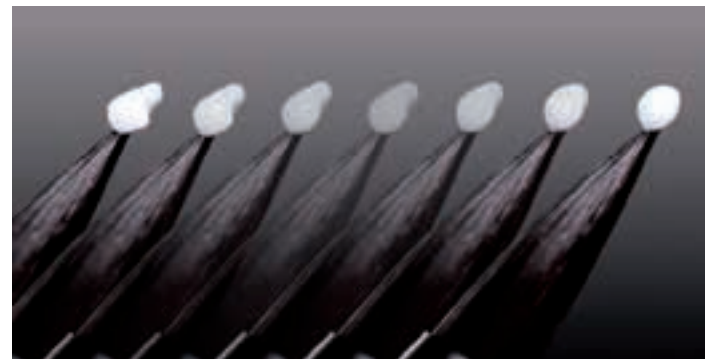

Description	Item no.
bRRRush aluminum handle	4000-AH-bRRR



4200-bRRR-1
N.era bRRRush #1,
complete brush

4201-1
Spare tips #1 (2 pcs)



4200-bRRR-Asst
N.era bRRRush, complete set :
#8, #6, #4, #1

[NJOY] N.ERA

The featherlight version of the N.era brush

On request of some customers, Smile Line has completed the N.era assortment with [Njoy]: **colorful, full of joy and good mood... but also extra-light N.era brushes!**

[Njoy] handle is hollow, injected out of ABS-thermoplastic and overmoulded with a soft-touch silicone for a very nice grip.

YOUR CUSTOMIZED SET

The [Njoy] concept allows you to **compose your own set of brushes according to your own tastes.** Enough to determine the color you wish to receive for each of the four sizes in the set – see item numbers on the right. Your Smile Line partner will be glad to compose your personal and customized set!

Important: N.era [Njoy] brushes have no interchangeable tips. We chose that option mainly in order to diminish the weight of the instrument. Of course, it has a positive impact on its retail price while keeping all the advantages of N.era.



SMILELINE 2017

Mojito

#8 4200-MOJ-8	#4 4200-MOJ-4
#6 4200-MOJ-6	#1 4200-MOJ-1

Bloody Mary

#8 4200-BLO-8	#4 4200-BLO-4
#6 4200-BLO-6	#1 4200-BLO-1

Sex on the beach

#8 4200-SOB-8	#4 4200-SOB-4
#6 4200-SOB-6	#1 4200-SOB-1

Cosmopolitan

#8 4200-COS-8	#4 4200-COS-4
#6 4200-COS-6	#1 4200-COS-1

Blue Lagoon

#8 4200-LAG-8	#4 4200-LAG-4
#6 4200-LAG-6	#1 4200-LAG-1

Yellow cab

#8 4200-YEC-8	#4 4200-YEC-4
#6 4200-YEC-6	#1 4200-YEC-1

H₂O

Hygiene, logic,
ergonomic

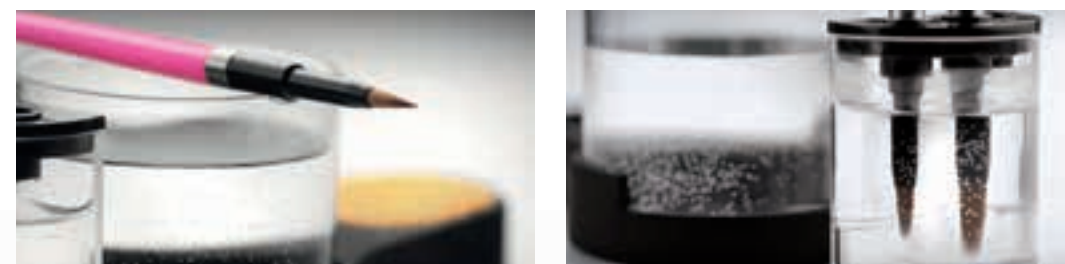

H₂O is the essential accessory which completes your porcelain working station, at the right or at the left of your mixing tray. This universal station allows you to **rinse your brush in fresh water, to smoothen** it in order to **give it the sharpest possible tip** on a viscose sponge and finally to store it, vertically dipped in water in an separate container.

All H₂O components are independent, which means that you can change the water of the main container without having to touch the storage container... or vice versa. Thanks to the design of the base and the attachment of the storage container, you can decide the position in an angle of 60°, depending on your preference or of the fact your are left or right handed.



Description	Item no.
H ₂ O, complete set: black base, round container, stock recipient with lid, viscose sponge (2 pcs)	4400
H ₂ O, round container, 1 pc	4410
H ₂ O, storage container with lid, 1 pc	4420
H ₂ O, viscose sponges, 2 pcs	4430

PORCELAIN TRAYS

SMILELINE 2017



Ultimate
development!



SLIM PAD

SMILELINE 2017

The essential... without
compromises

Porcelain mixing trays is a historic topic for Smile Line: it is the very first product we developed in 1994, profiling us as pioneers thanks to the legendary U-mid tray that revolutionized the habits in the way porcelain powders are conditioned.

In the following pages, we are anxious to introduce you Smile Line's latest models that take advantage of **more than 20 years experience, customer feedback and developments.**



SLIM PAD

WET'N'DRY

SMILELINE 2017



The benefits of the nano-technology

Our latest model SlimPad is the synthesis of listening to all the demands and suggestions that came from our customers! We are quite proud of the final result proposed by our design team.

The most important specifications have totally been respected in design :

- **Working base as flat and close as possible to the bench's surface : 10 mm high only!**
- **Working surface as close as possible to the front part : 20 mm**
- **Very compact and minimalist design**
- **Laptop format easy and light to carry**
- **Stackable**
- **Removable lid**
- **Working surface of 240 x 135 mm**

Wet'n'Dry SlimPad is supplied with a glass slab with six slots that have been precisely machined. Black PVA filter strips are inserted vertically for absorbing the liquid from the reservoir and bring it onto the surface for keeping your porcelain at the desired consistency for as long as there is liquid.

NANO-hydrophobic

Along with your SlimPad, you will receive a small bottle of a revolutionary liquid : "NANO-hydrophobic solution". It is a chemically engineered product with which you can very easily treat the surface of your glass slab. By doing this, you drastically reduce the surface tension of the glass.

The impact on your prepared powders is absolutely amazing : instead of spreading out and compacting with the time, **your porcelain masses keep a wonderful cohesion, the working area stays cleaner** – in short working comfort is improved!



Description	Item no.
Wet'n'Dry SlimPad complete set: 1 container with lid, glass slab with slots, 10 black filter-strips, NANO-hydrophobic solution 15 ml	13090
Spare glass slab 240 x 135 x 4 mm, 10 black filter-strips, NANO-hydrophobic solution 15 ml	13091
"The Black Ones", black PVA filter-strips, 10 pcs	11094-B
NANO-hydrophobic solution, 15 ml	1160

WET'N'DRY EVO 3

SMILELINE 2017

Wet'n'Dry EVO3 benefits of the same technology as SlimPad presented on pages 24-25. Working surface dimensions are also 240 x 135 mm.

EVO3 container makes the difference: the irresistible profile of its base allows the opportunity to integrate a drawer containing a stains tray in the front part. This makes EVO3 two trays in one!

Background color – your choice: you'll receive with your EVO3 three x-thin (0.3 mm) opaque PVC screens that you'll place under the glass slab. Depending on your preference, you can chose between a white... a grey... and a black background for your working surface.



Breathtaking design
and ergonomics

Description	Item no.
Wet'n'Dry EVO3, complete set incl.: container-lid with drawer for stains, glass slab with slots, 3 x-thin PVC screens (white-grey-black), 10 black PVA filter-strips, U-mid ADVANCED Liquid 100 ml, U-mid Stains Liquid 15 ml, NANO-hydrophobic solution 15 ml	12090
Spare glass slab 240 x 135 mm, incl. 3 x-thin PVC screens (white-grey-black), 10 black PVA filter-strips, NANO-hydrophobic solution 15 ml	11091
"The Black Ones", PVA filter-strips, 10 pcs	11094-B
Wet'n'Dry, x-thin PVC screens (white-grey-black), 3 pcs	11095
NANO-hydrophobic solution, 15 ml	1160



U-MID CLASSIC

U-MID : A CLASSIC SINCE MORE THAN 20 YEARS

Since its launch in 1994, U-mid has become worldwide a classic in the segment "wet trays for porcelain". Its great and undeniable advantages for everyday techniques are: **automatic "wetting" of the powders - permanent consistency - no mixing required - time saving and wonderful working conditions - savings in ceramic powders - ergonomics.** The U-mid Classic is the standard for all levels of technicians, beginner to expert.

Pioneers thanks to hi-tech components

The combination of capillary filters offers great reliability. The ceramic porous plate transports moisture from the reservoir to the surface. At the same time the top-layer microporous membrane-filter works as a humidity regulator and a very smooth working surface. Both components are easy to maintain: the ceramic porous plate can be thoroughly steam cleaned and the microporous membrane-filter can be gently rinsed under running water. U-mid Classic is available in standard format (240 x 135 mm) and in a small version, Light U-mid (150 x 73 mm). As an option, Smile Line offers a black microporous membrane-filter to be put over the traditional white membrane for the standard format only.



Wet trays for porcelain

Description	Item no.
U-mid Classic complete set, inclu.: container/lid unit, ceramic porous plate, 2 white membrane-filters, U-mid Liquid ADVANCED 250 ml	1080
U-mid, ceramic porous plate, 240 x 135 x 6 mm	1081
U-mid, white membrane, 240 x 135 mm (2 pcs)	1074
U-mid, black membrane, 240 x 135 mm (2 pcs)	1076

U-MID EVO 3



The classic combination of capillary filters U-mid also exists for EVO3. The front part of the container is equipped with a drawer containing a stains tray.

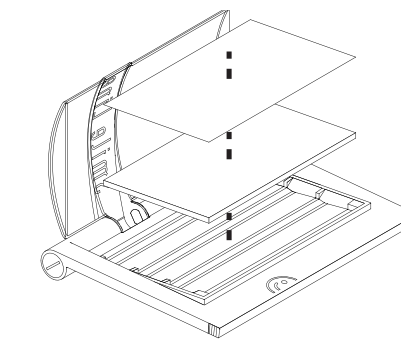

Description	Item no.
U-mid EVO3, complete set: container/lid with drawer for stains, ceramic porous plate, 2 white microporous membrane-filters, U-mid ADVANCED liquid 250 ml, U-mid Stains liquid 15 ml U-mid Stains Liquid 15 ml	2080
U-mid, ceramic porous plate, 240 x 135 x 6 mm	1081
U-mid, white membrane, 240 x 135 mm (2 pcs)	1074
U-mid, black membrane, 240 x 135 mm (2 pcs)	1076

TINTO

SMILELINE 2017

Tinto mixing trays allow you to store premixed products like stains or paste-opaques, protected from dust. Although they are of a traditional concept (dry tray, reinforced polypropylene), Tinto trays profile themselves with their unique **design, ergonomics and compactness** (118 x 118 x 25 mm). The lid is equipped with a panoramic transparent window made out of polycarbonate and allow you to recognize the contents of the tray at a glance.

Nowadays it is quite common that the same dental laboratory is using **several brands of porcelains**.

Tinto was thought in order to be **stacked one over the other**, saving this way much bench space. It will be childplay to indicate on the side with a marker the reference of the product on the inside.

Two models are available. The first has 9 wells of 18 mm diameter and a smaller deeper well for the liquid. The second model has 15 wells of 14 mm diameter as well as two small-deep wells for the liquid.

Tinto is supplied with two pieces, either two identical models, or one of each.

Compact
and airtight



Description	Item no.
Tinto, set of 2 trays with 9 and 15 wells	1300
Tinto, set of 2 trays with 9 wells	1309
Tinto, set of 2 trays with 15 wells	1315

WAX AND COMPOSITE

SMILELINE 2017



Superior quality
Made in Switzerland

WAX INSTRUMENT SET

INSTRUMENT BY SMILE LINE

Tradition, highest quality, **manufacturing in Switzerland and in Europe exclusively**. Wax instruments by Smile Line represent what is best in its kind. You will purchase the set once and your instruments will accompany you during many years of your dental artistry.

Note: all the modules shown on this page are obviously compatible with the handles on pages 6-7.

Highest quality
in tradition

SMILE LINE 2017



- 4000-CS**
Scalpel module
- 4000-D**
Lecron module
- 4000-E**
Zahle knife module
- 4000-F**
Zahle spatula module
- 4000-G**
Spoon short module
- 4000-H**
1/2 Hollenback module
- 4000-I**
PK Thomas module
- 4000-J**
Needle module



- 4000-S**
Beale spatula module
- 4000-T**
Beale tip module

4001-CS
Scalpel blades
(10 pcs)



14060
Wax Instrument set:
10 instruments,
anodized aluminum
handles, micro-fiber
tissue



4000-U
Hammer module

Not included in
the set

HIGH PRECISION WAXES

Quality, confidence
and working comfort



2150
ADD-ON wax white,
30 g



2151
POSITION wax, 30 g



2160
High Precision
Margin wax red, 30 g



2161
High Precision Inlay
wax light green, 30 g



2162
High Precision
Modelling wax deep
green, 30 g

High Precision ADD-ON Wax

Specially studied for allowing you to produce your own veneers by casting the wax into the silicone moulds. It is 100% organic. By slightly heating up a wax-veneer you have produced with this wax, you can adapt its shape without fear of breaking it.

High Precision POSITION Wax

This wax is soft and sticky and allows you to fix the wax elements like veneers or occlusal tables you have produced thanks to the silicone moulds.

High Precision Margin Wax

This is a red wax with superior characteristics for modelling all marginal areas (copings and inlays). This wax has almost no retraction - inert wax.

High Precision Inlay Wax

Hard modeling wax, light green color, for occlusal surfaces & inlays. It is extremely comfortable to carve. Its qualities allow it to be used also for milling works. The surface obtained after casting or pressing is extremely smooth.

High Precision Modelling Wax

This is a universal, hard wax, deep green color, for modelling (copings, frameworks). It has a very low retraction, burns without leaving any residues and provides a very nice working comfort.

Smile Line's High Precision Waxes are all 100% organic.

SILICONE MOULDS

N-ARCHITECT ANTERIORS

SMILELINE 2017



Made out of transparent silicone, these moulds allow you to easily and rapidly produce your own wax or composite veneers.

The assortment is gathering beautiful basic shapes: triangular, oval, rectangular as well as a universal lower anterior form, all available in two sizes for a total of 8 moulds in the set.



Description	Item no.
New Architect, set of 8 anterior silicone moulds	2111

SILICONE MOULDS

N-ARCHITECT POSTERIOURS



N-Architect posterior moulds complete the assortment of anterior moulds described on the left page. Two upper and two lower sizes are supplied in the set.

These moulds are very useful for diagnostic wax-ups. They also allow to reach a production efficiency far superior to many other kinds of methods for pressable ceramics.

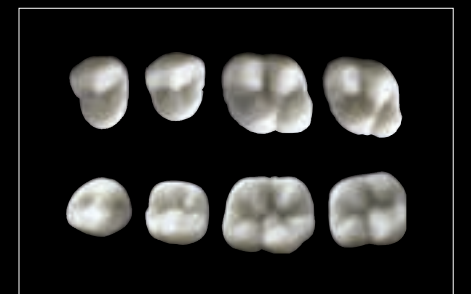

Description	Item no.
New Architect, set of 4 posterior silicone moulds	2121

COMPOSITE INSTRUMENT SET

INSTRUMENT MODULES FOR COMPOSITES

SMILELINE 2017

Modular, comfortable and innovative

All these tools are exclusively made in Switzerland and have been specifically developed for modeling of light curing composites. The three spatulas are produced out of a resilient stainless steel. The two white tips are made out of synthetic rubber. They provide the great advantage of being **totally non-sticky on composites** and are a dream for modeling.

Composite instruments are an integrated part of the program "Instrument by Smile Line" and compatible with all the handles described on pages 6-7.



- 4000-S1**
Composite spatula #1, module
- 4000-S2**
Composite spatula #2, module
- 4000-S3**
Composite spatula #3, module
- 4000-R1**
Rubber #1, Chisel, module
- 4000-R2**
Rubber #2, Cone, module
- 4010-S1**
Complete instrument (4000-AH + S1)
- 4010-S2**
Complete instrument (4000-AH + S2)
- 4010-S3**
Complete instrument (4000-AH + S3)
- 4010-R1**
Complete instrument (4000-AH + R1)
- 4010-R2**
Complete instrument (4000-H + R2)



14070
Set of 5 instruments for composite, anodized aluminum handle, micro-fiber tissue

COMPO-BRUSH

COMPOSITE STAINING

The new Compo-Brushes developed with Styleitaliano are intended for composite staining.

Their black synthetic fiber allow for **extreme precision with the best contrast**. A working quality superior to standard brushes you find normally in the composite kits. Brush tips hold by friction on their handle.

#000 Posterior brush tip can easily be bent by the user for a better access to the posterior areas.

Compo-Brush set contents two complete brushes and two replacement brush-tips of each model. Single brushes as well as brush tips refills are available separately.

Description	Item no.
Compo-Brush, set of 2 brushes and 2 spare tips ea. (2 x ANT & 2 x POST)	4650-Set
Compo-Brush, tips #000 for posteriors (50 pcs)	4651-POST
Compo-Brush, flat tips for anteriors (50 pcs)	4651-ANT



4650-POST
Compo-Brush, complete brush #000

4650-ANT
Compo-Brush, complete flat brush



STYLE ITALIANO
SHADE GUIDES

IMPLANTOLOGY ACCESSORIES

SMILELINE 2017



Comfort and ergonomics



IMPLANT DRIVERS

IMPLANT DRIVERS FOR LAB USE

SMILELINE 2017



Smile Line driver Nobel Biocare¹ compatible

4000-NOB driver end only
4010-NOB driver complete
4000-L-NOB driver end only, long
4010-L-NOB driver complete, long

Smile Line driver Straumann¹ compatible

4000-STR driver end only
4010-STR driver complete
4000-L-STR driver end only, long
4010-L-STR driver complete, long

Smile Line driver Astra Tech¹ compatible

4000-AST driver end only
4010-AST driver complete
4000-L-AST driver end only, long
4010-L-AST driver complete, long

Smile Line driver Friadent¹ compatible

4000-FRI driver end only
4010-FRI driver complete
4000-L-FRI driver end only, long
4010-L-FRI driver complete, long



Smile Line driver 3i¹ compatible

4000-iii-HX driver end only
4010-iii-HX driver complete
4000-L-iii-HX driver end only, long
4010-L-iii-HX driver complete, long
Available also with square head: replace HX by SQ on Item no.

Smile Line driver Camlog¹ compatible

4000-CAM driver end only
4010-CAM driver complete
4000-L-CAM driver end only, long
4010-L-CAM driver complete, long

Smile Line driver Ankylos¹ compatible

4000-ANK driver end only
4010-ANK driver complete
4000-L-ANK driver end only, long
4010-L-ANK driver complete, long

Smile Line driver SPI¹ compatible

4000-SPI driver end only
4010-SPI driver complete
4000-L-SPI driver end only, long
4010-L-SPI driver complete, long



4000-FRI

4000-As

4010-L-STR driver complete

4000-BC

Smile Line's implant drivers set has become an essential accessory in many dental laboratories.

It gathers 8 different models of screwdrivers compatible with the most popular dental implant systems on the market: Nobel Biocare, Straumann, Astra Tech, 3i, Camlog, SPI Ankylos, Friadent¹.

It is interesting to understand that the set will provide a compatible driver tip for the screws of the majority of implant systems that are not on our list.

The set is supplied with regular length driver tips but you also have the possibility to order every individual driver tip separately, for example for creating your own set with x-long tips.

Description	Item no.
Implant-Drivers Station, complete set incl. 8 implant drivers (standard length) and one solid aluminum cube, nature anodized	4300
Aluminum cube-station, nature anodized	4301
Aluminum cube-station, black anodized	4302



¹Nobel Biocare, Straumann, Astra Tech, 3i, Camlog, SPI, Ankylos, Friadent are all registered Trademarks.

SIDEKICK

IMPLANT DRIVERS CLINIC

SMILELINE 2017

Have you ever been unable to screw/unscrew an implant of a brand you are not familiar with or an extremely high or short length and you are missing that driver in your armamentarium? It is a very common problem to have.



Nobel Biocare¹ Compatible driver

- D-400-NOB-S Driver tip, 8 mm
- D-400-NOB-M Driver tip, 13 mm
- D-400-NOB-L Driver tip, 25 mm



Straumann¹ Compatible driver

- D-400-STR-S Driver tip, 8 mm
- D-400-STR-M Driver tip, 13 mm
- D-400-STR-L Driver tip, 25 mm



Astra Tech¹ Compatible driver

- D-400-AST-S Driver tip, 8 mm
- D-400-AST-M Driver tip, 13 mm
- D-400-AST-L Driver tip, 25 mm



Friadent¹ Compatible driver

- D-400-FRI-S Driver tip, 8 mm
- D-400-FRI-M Driver tip, 13 mm
- D-400-FRI-L Driver tip, 25 mm



3i¹ Compatible driver

- D-400-iii-S Driver tip, 8 mm
- D-400-iii-M Driver tip, 13 mm
- D-400-iii-L Driver tip, 25 mm



Camlog¹ Compatible driver

- D-400-CAM-S Driver tip, 8 mm
- D-400-CAM-M Driver tip, 13 mm
- D-400-CAM-L Driver tip, 25 mm



Ankylos¹ Compatible driver

- D-400-ANK-S Driver tip, 8 mm
- D-400-ANK-M Driver tip, 13 mm
- D-400-ANK-L Driver tip, 25 mm



SPI¹ Compatible driver

- D-400-SPI-S Driver tip, 8 mm
- D-400-SPI-M Driver tip, 13 mm
- D-400-SPI-L Driver tip, 25 mm



Flat driver 1.4 mm

- D-400-1.4-S Driver tip, 8 mm
- D-400-1.4-M Driver tip, 13 mm
- D-400-1.4-L Driver tip, 25 mm



D-401
Driver's head

Sidekick's box of screwdrivers for implantology gathers 9 models (each available in 3 lengths) that are compatible with the most popular implant systems on the market. The aim is that you have available, **anytime and immediately THE correct model and length of driver needed.**

Thanks to the wide choice of proposed geometries, in 99% of the cases you'll find a compatible model with other brands of implants' screws. A smart clipping mechanism allows you to quickly assemble/disassemble the driver's tip and the (very compact) head.

For completing the concept, Smile Line has created a special clamp forceps which tip is perfectly designed to match the profile of the driver's head for extra tightening or difficult un-tightening. Its use is extremely comfortable with a **with a direct access to the head's side** without removing the driver from its place.

Smile Line's box of implant drivers is available in two executions: the "basic" set that includes one driver tip of each in the medium size (9 tips + 1 head) or the "master" set that includes one driver tip of each in the three sizes (27 tips + 1 head).

Should you prefer to compose your own customized box, you may order all the components individually.



D-402
Clamp forceps



Ergonomic, universal
and comfortable



Description	Item no.
Sidekick implant drivers set, inclu. 9 tips 13 mm, 1 head, aluminum box	D-430-Basic
Sidekick implant drivers set, inclu. 27 tips (8-13-25 mm), 1 head, aluminum box	D-430-Master
Sidekick aluminum box, empty	D-499
Replacement o'ring for driver's head, 5 pcs	D-403

¹Nobel Biocare, Straumann, Astra Tech, 3i, Camlog, SPI, Ankylos, Friadent are all registered Trademarks.



SHADE MATCHING AND DENTAL PHOTOGRAPHY

SMILELINE 2017



Must have



SMILE LITE

SHADE MATCHING FOR THE SPECIALIST

Without the proper tool, shade-taking can become very risky and cause a source of failures when producing an aesthetic restoration. Several factors can influence an incorrect perception of true colors, like ambient light (intensity, quality) and the working environment. Even human factors like the level of stress or fatigue on the eye can cause shade-taking errors.

Smile Lite is a revolutionary tool which brings you reliability, simplicity and efficiency – it allows you to **drastically reduce the risk of mistakes during shade-taking.**

Equipped with 5500°K LEDs (light emitting diodes), Smile Lite provides natural and neutral light, stable and reliable regardless of the time of the day or the weather outside. A Li-Ion battery is integrated meaning that the device is easily rechargeable thanks to the mini-USB cable (cable and charger supplied in the set).

Light quality of Smile Lite allows you to **determine with ease and security the hue, value and chroma of natural teeth.**

The rectangular view finder through which the operator observes the teeth clearly limits the “working area” in order to avoid any outside interference.

SMILELINE 2017

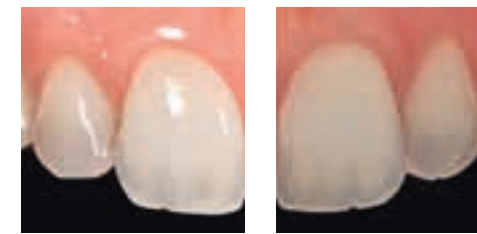

Without polarizing filter

With Style Lense polarizing filter



Observe teeth as you have never seen before!

Inspired from the works of famous lecturers and clinicians, among them L. Vanini (1996) and S. Papazoglou (2016), together with our partner Styleitaliano (a group of passionate researchers and clinicians – www.styleitaliano.org) we developed a special polarizing filter that produces near to zero light interference easily adaptable to Smile Lite.

This “magical” filter amazingly annihilates light reflection (specular and diffuse) and allows the user to **observe the teeth in a totally new way**: easier appreciation of color, better understanding of the depth and transparencies, enhancement of the tiniest details and characterizations.

The live-polarization filter is packaged as a set with the Smile Lite. The filter can be attached to the Smile Lite with magnets, which allows for easy connection or removal.



Description	Item no.
Smile Lite, complete set incl. Style Lense polarizing filter	6500
Polarizing filter Style Lense	6510



SMILE LITE MDP

MOBILE DENTAL PHOTOGRAPHY
BY PROF. LOUIS HARDAN

Nowadays, each new smartphone arriving on the market is equipped with a greater performing and amazing camera! It is for taking advantage of this revolution in progress that Smile Line proposes you **the very first device specially developed for allowing the most beautiful dental photos with your smartphone!**

SMILELINE 2017



6600
Smile Lite MDP,
Mobile Dental
Photography



Smile Lite MDP, that can be considered as a “mini photo studio”, took 3 years of development, research, and tests. The device is equipped with three groups of LEDs (light emitting diodes). Each group can be lit up individually, while you also have the possibility to set the power of illumination thanks to a dimmer (four different steps of power).

The back of Smile Lite MDP is equipped with a universal adaptor that is adjustable for **any model of smartphone** having a width between 55-85 mm.

Smile Lite MDP is a plug and play device that is very easy to use and that doesn't need any special App, calibration process or specific education. It will allow you to drastically improve your results with the camera of your smartphone... very easily, simple, and compact. Soon it will become a mandatory tool for you:

- **Photos for shade taking**
- **Every day communication with the lab**
- **Short video clips**
- **Patients' documentation**
- **Artistic pictures**



Passionate users will be happy to know that some accessories are available as an additional option. Thanks to these accessories, you'll have the possibility to take pictures with a **polarizing filter** (item.no 6620) or with **diffusors** (item.no 6610) for even more professional results.

Description	Item no.
MDP, lateral diffusors (2 pcs)	6610
MDP, polarizing filter	6620



Un-retouched images realized with smartphones + Smile Lite MDP.

FLEXIPALETTE

In partnership with Styleitaliano, a study group of passionate clinicians and researchers, Smile Line introduces on the market an assortment of very unique and innovative contrastors intended for intra-oral photography: Flexipalette.

Flexipalette is made out of a bendable copper sheet 100% overmoulded with a medical grade silicone rubber, latex free, safe and hypoallergenic.

- Flexipalette can be sterilized in autoclave at 135°C
- Flexipalette is absolutely opaque and reflection-free
- Flexipalette is gentle and soft in the patient's mouth
- Flexipalette can be folded in a 30° to 45° degree angle

When visiting Smile Line's website, you'll discover an instructive video-clip demonstrating you how to use Flexipalette and its great advantages.

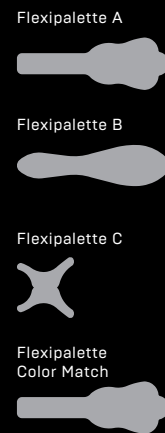

With Flexipalette

Without Flexipalette

A must have for
intra-oral photography



Description	Item no.
Flexipalette, set of 4 forms	FP-3100
Flexipalette, form A	FP-3001
Flexipalette, form B	FP-3002
Flexipalette, form C	FP-3003
Flexipalette, Color Match	FP-3004



PHOTOCAD

A NEW GENERATION OF RETRACTORS



The innovative design of the Photo-CAD retractors allows for the best results with photography of the 4 quadrants and during digital impressions with Cad CAM systems. Photo-CAD can be ergonomically folded and adapted to the patient's mouth and to the needs of the photographer. They have a soft surface for the patients' best comfort. **The material is opaque, reflection-free** and can be sterilized.

Photo-CAD LOW is a totally unique tool which allows for the retraction of both the cheek and the tongue in the same use during an "occlusal" image capture of a lower quadrant. It allows to make the arch free by keeping aside the soft tissues. Photo-CAD LOW also makes optical scanned-impressions of lower preparations easier.

Photo-CAD UP is a cheek retractor which can be used every day. Its function when in use for dental photography will be to retract the vestibular soft tissues in the area upper pre-molar/ molar during "occlusal" image capture. It will be of great help too during optical scanned-impressions for Cad-CAM systems.

Description	Item no.
Photo-CAD, set of 3 pcs	PC-3100

MY SHADE GUIDE

Shade guides supplied by the industry are commonly used; although everyone agrees on the fact that often there is a lack of accuracy in color vs. the products used.

Our aim with My Shade Guide is to offer you the possibility to **easily make your own shade guides based on your own reality**. The set contains synthetic rubber mould, separator, all the small supports, sticks and clips and the box for collecting all the finished parts.

Note: My Shade Guide exists also in version for making teeth samples out of composite [specific mould] – all information available under www.smileline.ch

Create your own shade guide

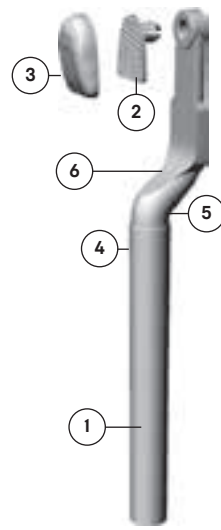

- 1 Stick
- 2 Clip
- 3 Porcelain sample
- 4 Friction zone
- 5 Anatomic design
- 6 Marking surface

SMILELINE 2017

SAMPLER

This very precise tool allows you to produce porcelain tabs of a determined thickness **from your personal blends** in a very simple and professional way. It is also extremely useful as well for **porcelain firing tests**. It also allows you to produce precise and accurate **tabs out of light curing composite**.

The porcelain portionners allow you to take the exact volume of ceramic powder out of the bottle. They are a need for all precise measurements. Portions taken are of 50, 25, 5 and 1 (mm³) depending on the instrument end chosen.

The black tablets are out of laminated card stock and give you the possibility of gluing and indexing all your tabs for complete customization.

Sampler for porcelain and for composite



Description	Item no.
My Shade Guide, complete kit: solid aluminum base with PC lid, 5 holders, 25 sticks & clips, 1 synthetic rubber mould, 8 ml porcelain separating fluid, 2 build-up glass slabs, 2 x-thin blades	7500-N

MORE INFORMATION ON WWW.SMILELINE.CH



Description	Item no.
Complete kit, incl. sampler, portionners 50-25 and 5-1, indexing tablet	7010
Sampler only	7015
Indexing tablet, 5 pcs	7016
Portionner 50-25	4010-A
Portionner 5-1	4010-B

ACCESSORIES

SMILELINE 2017



Efficiency - Productivity



MICRO-VIBES

Good vibrations!

SMILELINE 2017

Micro-Vibes is a vibration tool, pen like size, that exists in two executions:

01000-MVS – equipped of a spatula, it has two main functions:
When you combine the vibrating action when mixing your porcelain, you allow the micro-bubbles of air to be extracted.

The tool allows you to add porcelain portions into the interdental spaces and condense them locally and very precisely. All the spaces will be closed after the second firing cycle.

01000-MVOP – equipped with the small Al_2O_3 bead:
It allows you to apply opaques (powder or paste) and liners in an extremely thin, dense and regular layer.

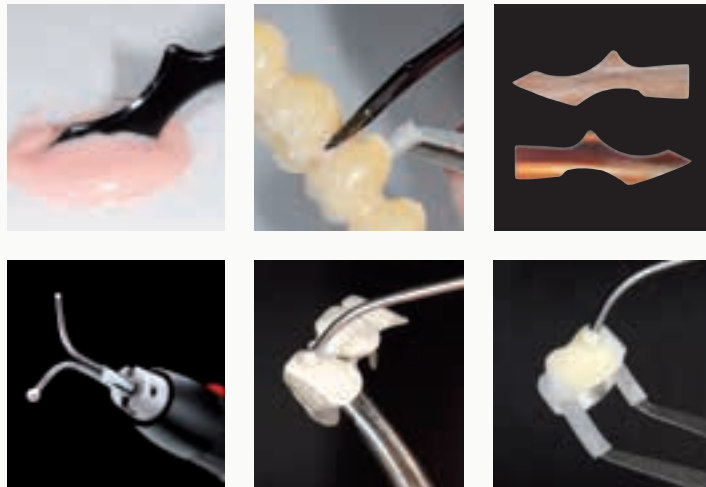

01000-MVOP
Micro-Vibes instrument with Al_2O_3 bead for paste opaques

01000-MVS
Micro-Vibes instrument with universal flexible spatula

Available options:

Description	Item no.
Spare tips with double Al_2O_3 bead, for opaques and liners	01025-MV
Universal spatula in natural fiber (2 pcs)	01011-MV



MORE INFORMATION ON
WWW.SMILELINE.CH

UNITED COLORS OF D.VINCI

Clear identification of your powders during porcelain build-up

A very small quantity of United Colors added to your porcelain mix will brighten it with the selected color. When choosing a different color for each of the mass used, you'll have an **extremely precise and detailed perception of your build-up.**

Thanks to the plasticity of the product you won't see the different colors mixing with each other. United Colors of D. Vinci fire without leaving residues.

Caution: It is important to extend the pre-drying time of the porcelain. Supplied colors are concentrates and are not meant to be used pure – see also our video clip on www.smileline.ch



5200-Asst
Intensive fluo colors for porcelain build-up, set of 7, 10 ml ea.



GOLDEN SECTION DIVIDER

The golden proportion is a ratio which result is called mathematically Phi (1.618) or phi (0.618). It is proven that **the universe uses this proportion for its own construction**, from the genetic sequences up to the level of galaxies, passing by construction of flowers, insects, a hand, a face or the whole body.

As we are able to divide a line by its middle or draw a perpendicular, we all recognize the Golden Proportion as a constant for harmony and balance.



Description	Item no.
Golden Section Divider set, including an assortment of 6 grids blocs, instructions	6010

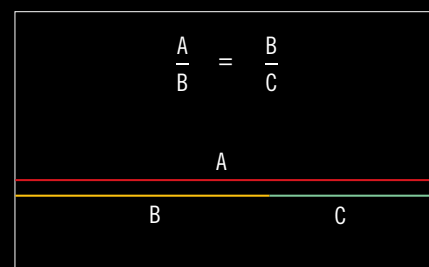

For the determination of the Golden Proportion

55 144 723 377 110 987 1597 7554 4181 6 10348 17711 28657 46 1075 121393 18 17811

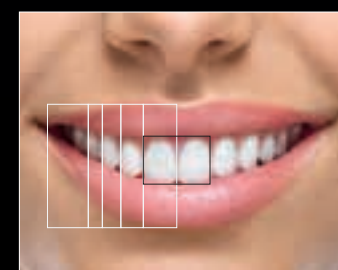

FASCINATING TOOL

Golden Section Divider will **allow you to easily assimilate "physically" the concept**. Slightly or widely open, the Golden Section Divider indicates always two segments respecting the golden proportion. Made out of the highest quality stainless steel and very carefully assembled by hand, the divider is a wonder of precision mechanics. It is supplied together with an assortment of the very useful blocs of grids and of course with instructions of use.



THE GOLDEN PROPORTION IN DENTISTRY

Many studies mention the golden proportion as being one of the ingredients for the harmony of a smile and dentition (see images). The Golden Section Divider and the grids allow you to discover in a few seconds the theoretical ideal goal in comparison to the real situation in the mouth. These informations are very exciting and very useful for :

- **esthetic anterior cases**
- **dentures**
- **positioning-angle-axis of teeth**
- **gingivectomy**
- **wax-up control**



The "Golden Section Grids" printed on paper (assortment of blocs supplied in the kit) are very useful for registrations in the mouth of a patient as well as when working with a model.

VENEER ME

Thanks to veneerME, you'll be able to carry and ship and also manipulate your hyper-delicate veneers in the highest conditions of security!

Maximum security
for your veneers



Description	Item no.
veneerME, set of 3 complete boxes, 3 spare PU pads and 3 spare membrane-frames	2600
veneerME, spare PU pads (10 pcs)	2610
veneerME, spare membrane-frames (10 pcs)	2620

The sticky polyurethane gel-pad

The base of veneerME box is covered with a sticky pad out of polyurethane gel. Veneers are placed on this pad on their buccal surface, and adhere naturally. All the preparation process of the internal part of the veneer (acid etching, silanization) can be done in this position **without any fear of a veneer escaping or falling on the floor**. The pad's material is super resistant and can be re-used several times (it is easily replaceable in case of deterioration).

The security membrane-frame

Once the veneers are secured on the pad, the membrane-frame is clipped on the base of veneerME box for extra fixation. The xx-thin membrane, made out of nylon, delicately adapts to the shape of the veneers. This done, you just need to close the lid and your master work is ready for delivery. The membrane-frame can be replaced -if needed- after having been used several times.

Huge advantage: the membrane is permeable! In other words the clinician can proceed with rinsing and drying after having replaced the membrane-frame on the base. This way the clinician can work in the best conditions and in total security.



HOLDING GEL

Gel for temporarily
fixation

A small drop on the die is enough for holding very well – and temporarily – your delicate porcelain veneers as well as your full-ceramic restorations on the model.

This gel is essential for **checking the contact points, for the application of correction powders with great ease and for restorations that oppose each other.**

Transparent, so it doesn't alter the shade – it completely dissolves in water and doesn't leave any residue after firing.



Description	Item no.
Holding gel, 2 x 6 ml	5110

ZIR.CARE

From the first moment you begin working with Zir.Care, **you'll experience new sensations**: efficacy, softness and comfort as you have never seen.

Zir.Care is in fact multi-functional: due to the number and shape of the diamond grains, it is engineered for zirconia oxide grinding and its use on layered porcelain is just amazing!

Zir.Care is not manufactured from the traditional channels of diamond disc producers in the dental industry. Instead, it is the object of specific and exclusive development with and for Smile Line.

- **fantastic grinding efficacy**
- **fine grain tool**
- **durability**
- **excellent on zirconia oxide as well as on layered porcelain**

Sinter diamond for zirconia oxide



ZC-20L

Zir.Care, sinter diamond, lense, 20 x 2 mm

ZC-20W

Zir.Care, sinter diamond, wheel 20 x 4 mm

ZC-12WS

Zir.Care, sinter diamond, wheel small, 12 x 2 mm

Description

Zir.Care set, inclu.: 3 sinter diamonds for zirconia oxide & 1 cleaning stone
Zir.Care Cleaner, cleaning stone

Item no.

ZC-00-Asst
ZC-cleaner

SMILELINE 2017

ORGAN.EZ

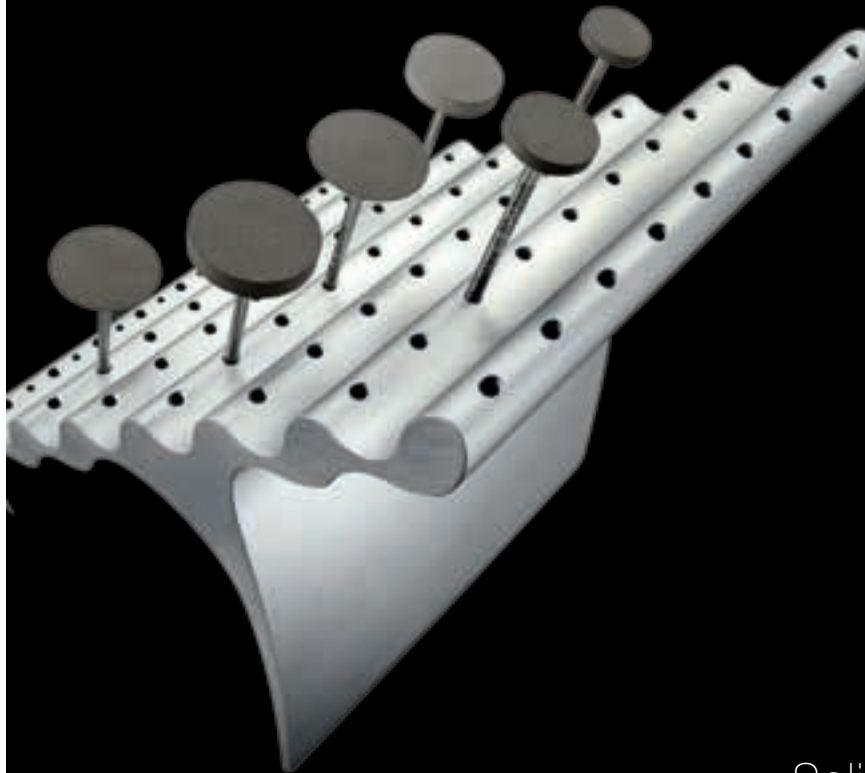

Solid aluminum burstand

At first sight, some will see a sculpture placed on the bench. Don't be misled: **ORGAN.EZ** is first and foremost extremely useful and ergonomic.

ORGAN.EZ allows you to **systematically arrange** your burs, diamonds, polishers with a simple notion – knowing instantly where to find them instead of having to search.

Made out of solid aluminum, ORGAN.EZ is very stable where you place it. For a maximum comfort when taking or replacing the burs, the entrance of each hole starts with a slight angle.

A maximum of 63 instruments with a shaft 2.35 can be placed. On the first level, you'll notice 8 additional holes intended for the placement of your air-turbine burs.



8100
Organ.ez, solid aluminum stand for HP & FG burs

INTERACTIVE

Smile Line's catalogue is traditionally produced every second year. During those two years, obviously we develop and launch on the market more innovative products and developments. You can discover them in real time on our regularly updated website www.smileline.ch



SMILELINE 2017

CONCLUSION

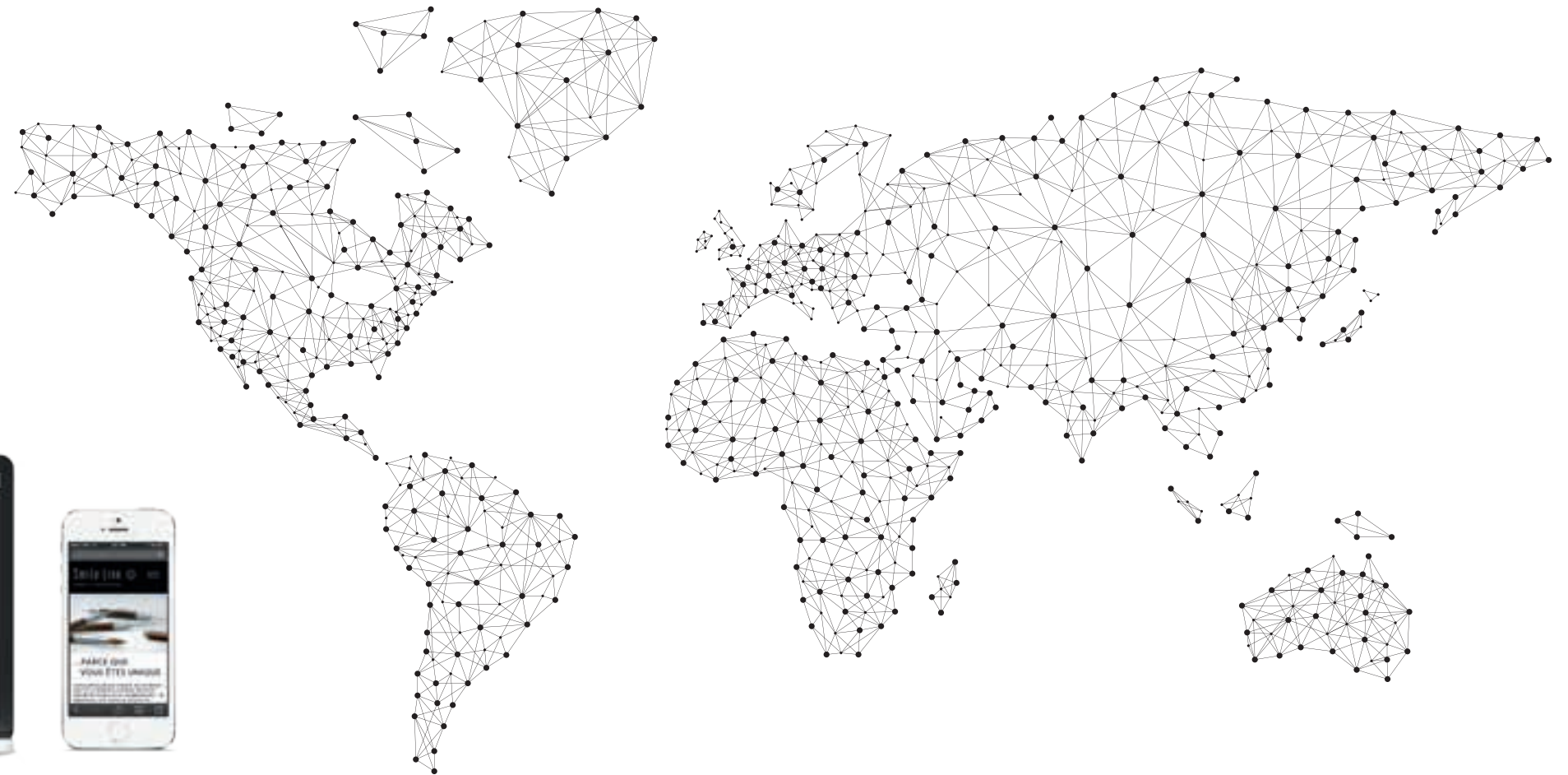

You have just discovered the philosophy of Smile Line and we hope some of our passion as well.

Don't wait – contact the Smile Line partner for your country today: the contact information is on the back of our catalogue. Should no other address be mentioned, you'll easily find it on the "dealers" page of our website.

For the case you have a very specific question to which our partner was not able to answer, you are welcome to contact us anytime per e-mail mail@smileline.ch. Our rule is to answer everyone in the shortest possible time.

We would like to use these last lines for warmly thanking everyone who has taken part in the development of Smile Line, or simply making our existence possible: all our qualified and motivated employees, our consultant and pilot lab Jan Kaech in Thun, our subcontracting companies, communication agency, importers, enthusiastic sales people and finally, most importantly, you: the user of Smile Line products.

EDUCATION CENTER

Learn, meet, share...

Thanks to the increasing and overwhelming success of Smile Line on the international markets and in order to be able to work in the best conditions, an extension of our building was necessary in 2015-2016.

It was for us the opportunity to achieve a project that was a dream during the years: the creation of an education center completely equipped, with 14 working spaces around a huge table of 6 m x 2 m, and all the necessary modern equipment.

In 2016, we were able to welcome several worldwide famous experts for porcelain hands-on courses. Throughout 2017 and beyond our program will continue, evolve and even diversify.

The events' program is updated and visible online – <http://smileline.ch/en/education-center>

This amazing space was created for you! We sincerely hope we'll have the chance to welcome you soon!





Smile Line ☺

made in switzerland

Smile Line SA
ZI La Clef 5
PO Box 229
CH-2610 St-Imier · Switzerland
Tel. +41 32 944 22 44
Fax +41 32 944 22 45
mail@smileline.ch
www.smileline.ch